



TECHNICAL
DATA

LUDOWICI
ROOFTILE®

Flat Shingle Tile

Flat Slab

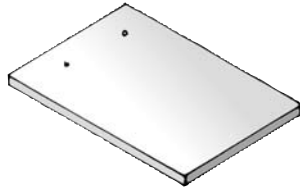

General Information

Thickness	Overall Size	Average Exposure	Pcs./Square	Lbs./Square	Minimum Slope
3/8"	6" x 12"	6" x 5"	480	1,300	5:12
5/8"	6" x 12"	6" x 5"	480	1,780	5:12

Flat Tile Accessories

Tile Type	Long Top	Short Top	End Band	Under Eave	Header Course*
Actual Size	6" x 9"	6" x 5"	3 1/2" x 12"	7" x 7"	6" x 12"
Exposure	6" x 5"	6" x 5"	3 1/2" x 5"	7" x 7"	6" x 9"
Pieces/Box	80	80	80	80	80
Weight 3/8"	3.6 lbs./ft.	2.0 lbs./ft.	2.9 lbs./ft.	2.8 lbs./ft.	3.2 lbs./ft.
5/8"	6.1 lbs./ft.	3.4 lbs./ft.	4.9 lbs./ft.	4.7 lbs./ft.	5.4 lbs./ft.

*See Option V-Hip & Ridge Accessories, Page 3.

Flat Shingle Tile

Antique, Brittany

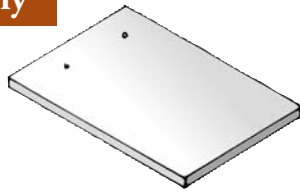

General Information

	Overall Size	Average Exposure	Pcs./Square	Lbs./Square	Minimum Slope
<i>Antique</i>	7" x 12"	7" x 5"	412	1,650	5:12
<i>Brittany</i>	7" x 12"	7" x 5"	412	1,900	5:12

Flat Tile Accessories

Tile Type	Long Top	Short Top	End Band	Under Eave	Header Course*
Actual Size	7" x 9"	7" x 5"	3 1/2" x 12"	7" x 7"	7" x 12"
Exposure	7" x 5"	7" x 5"	3 1/2" x 5"	7" x 7"	7" x 9"
Pieces/Box	80	80	80	80	80
Weight <i>Antique</i>	5.5 lbs./ft.	3.0 lbs./ft.	5.1 lbs./ft.	4.3 lbs./ft.	5.7 lbs./ft.
<i>Brittany</i>	6.1 lbs./ft.	3.4 lbs./ft.	5.7 lbs./ft.	4.7 lbs./ft.	6.3 lbs./ft.

*See Option V-Hip & Ridge Accessories, Page 3.

Flat Shingle Tile continued on next page.

Flat Shingle Tile (continued)

Calais, Colonial, Norman, Provincial

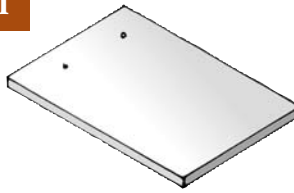

General Information

Tile Type	Overall Size	Average Exposure	Pcs./Square	Lbs./Square	Minimum Slope
<i>Calais</i>	7" x 15"	7" x 6 1/2"	317	1,600	5:12
<i>Colonial</i>	7 3/8" x 14 5/8"	7 3/8" x 6 5/16"	310	1,800	5:12
<i>Norman</i>	7" x 15"	7" x 6 1/2"	317	1,600	5:12
<i>Provincial</i>	7" x 15"	7" x 6 1/2"	317	1,575	5:12

Flat Tile Accessories

Tile Type	Long Top	Short Top	End Band	Under Eave	Header Course*
Actual Size	7" x 10 1/2"	7" x 6 1/2"	3 1/2" x 15"	7" x 8 1/2"	7" x 15"
Exposure	7" x 6 1/2"	7" x 6 1/2"	3 1/2" x 6 1/2"	7" x 8 1/2"	7" x 12"
Pieces/Box	80	80	80	80	80
Weight	7.1 lbs./ft.	4.4 lbs./ft.	5.5 lbs./ft.	5.7 lbs./ft.	5.9 lbs./ft.

*See Option V-Hip & Ridge Accessories, Page 3.

Crude

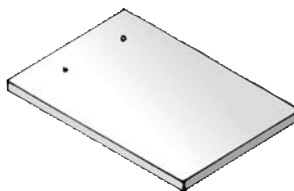

General Information

Overall Size	Average Exposure	Pcs./Square	Lbs./Square	Minimum Slope
6" x 12"	6" x 5"	480	1,935	5:12

Flat Tile Accessories

Tile Type	Long Top	Short Top	End Band	Under Eave	Header Course*
Actual Size	6" x 9"	6" x 5"	3" x 12"	6" x 7"	6" x 12"
Exposure	6" x 5"	6" x 5"	3" x 5"	6" x 7"	6" x 9"
Pieces/Box	80	80	80	80	80
Weight	6.7 lbs./ft.	3.4 lbs./ft.	4.9 lbs./ft.	4.7 lbs./ft.	5.4 lbs./ft.

*See Option V-Hip & Ridge Accessories, Page 3.

Flat Shingle Tile continued on next page.

Flat Shingle Tile (continued)

Georgian

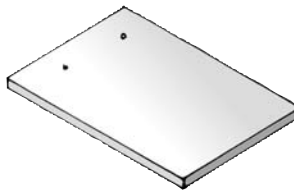

General Information

Overall Size	Average Exposure	Pcs./Square	Lbs./Square	Minimum Slope
8" x 15"	8" x 6 1/2"	276	1,600	5:12

Flat Tile Accessories

Tile Type	Long Top	Short Top	End Band	Under Eave	Header Course*
Actual Size	8" x 10 1/2"	8" x 6 1/2"	4" x 15"	8" x 8 1/2"	8" x 15"
Exposure	8" x 6 1/2"	8" x 6 1/2"	4" x 6 1/2"	8" x 8 1/2"	8" x 12"
Pieces/Box	80	80	80	80	80
Weight	7.1 lbs./ft.	4.4 lbs./ft.	6.2 lbs./ft.	5.7 lbs./ft.	6.8 lbs./ft.

*See Option V-Hip & Ridge Accessories below.

Note:

The V-Hip & Ridge Accessories can be used in place of Header Course tile with Flat Shingle field tiles.

V-Hip & Ridge Accessories

Tile Type	V-Hip & Ridge Regular 116°	V-Hip & Ridge Intermediate 90°	V-Hip Starter Regular	V-Ridge Closed Ridge End Regular* (Starter Shown)	V-Hip & Ridge Terminal 2H-1R* (Starter Shown)
<i>Interlocking, Interlocking XL</i>					
Actual Size	14 1/4"	14 1/4"	15 1/2"	14 1/4"	—
Exposure	12"	12"	12"	12"	—
Pieces/Box	38	32	4	4	2
Weight	7.4 lbs./ft.	7.7 lbs./ft.	8.0 lbs./pc.	8.0 lbs./pc.	15.0 lbs./pc.

*Starters and Finishers available, specify pitch of all sides of roof.

Interlocking Tile

**Americana, Classic, Lanai,
Williamsburg**

All XL Tile types included.



General Information

Tile Type	Overall Size	Average Exposure	Pcs./Square	Lbs./Square	Minimum Slope
<i>Interlocking</i>	9" x 14"	8 1/4" x 11"	158	800	3:12
<i>Interlocking XL</i>	10 5/8" x 16"	10" x 13"	111	700	3:12

Field Tile Accessories

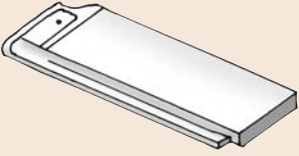
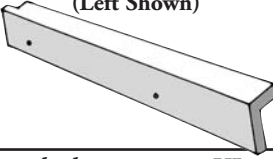
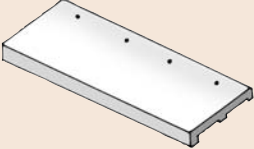
Tile Type	End Band		Detached Gable Rake Right & Left (Left Shown)		Under Eave	
						
<i>Interlocking/Interlocking XL</i>	<i>Interlocking</i>	<i>XL</i>	<i>Interlocking</i>	<i>XL</i>	<i>Interlocking</i>	<i>XL</i>
Actual Size	14"	16"	14"	16"	12"	12"
Exposure	11"	13"	11"	13"	12"	12"
Pieces/Box	80	80	150	150	150	150
Weight	3.3 lbs./ft.	4.2 lbs./ft.	1.6 lbs./ft.	2.1 lbs./ft.	2.3 lbs./ft.	2.3 lbs./ft.

V-Hip & Ridge Accessories (No. 118 & 211 Hip & Ridge Accessories on next page)

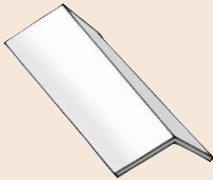
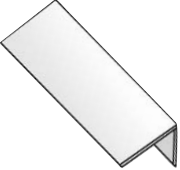
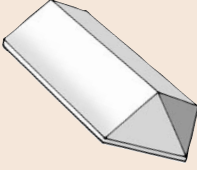
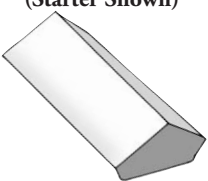
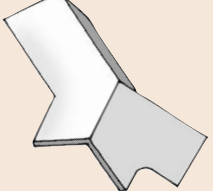
Tile Type	V-Hip & Ridge Regular 116°	V-Hip & Ridge Intermediate 90°	V-Hip Starter Regular	V-Ridge Closed Ridge End Regular* (Starter Shown)	V-Hip & Ridge Terminal 2H-1R* (Starter Shown)
					
<i>Interlocking, Interlocking XL</i>					
Actual Size	14 1/4"	14 1/4"	15 1/2"	14 1/4"	—
Exposure	12"	12"	12"	12"	—
Pieces/Box	38	32	4	4	2
Weight	7.4 lbs./ft.	7.7 lbs./ft.	8.0 lbs./pc.	8.0 lbs./pc.	15.0 lbs./pc.

Interlocking Tile continued on next page.

Interlocking Tile (continued)

Americana, Classic, Lanai, Williamsburg

All XL Tile types included.

No. 118 & No. 211 Hip & Ridge Accessories

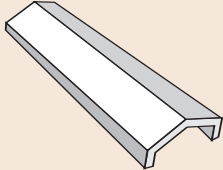
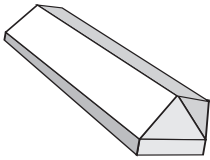
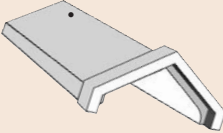
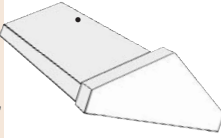
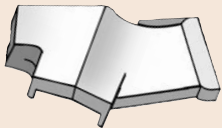
Tile Type	118 Hip Roll	168 Hip Starter	211 Ridge 116°	211 Ridge Closed End* (Starter Shown)	118/211 Terminal 2H-1R* (Finisher Shown)
					
<i>Interlocking</i> <i>Interlocking XL</i>					
Actual Size	14"	14"	13 1/4"	13 1/4"	—
Exposure	12"	12"	12"	12"	—
Pieces/Box	30	4	18	2	2
Weight	4.8 lbs./ft	5.0 lbs./pc.	9.7 lbs./ft.	14 lbs./pc.	20 lbs./pc.

*Starters and Finishers available, specify pitch of all sides of roof.



Imperial Slate, Celadon Ceramic Slate, Aspen Shake



General Information

	Overall Size	Average Exposure	Pcs./Square	Lbs./Square	Minimum Slope
<i>Imperial Slate</i>	10 3/16" x 16"	9 1/2" x 13"	117	890	3:12
<i>Celadon</i>	10 5/8" x 16"	10" x 13"	111	598	3:12
<i>Aspen Shake</i>	10 5/8" x 16"	10" x 13"	111	598	3:12

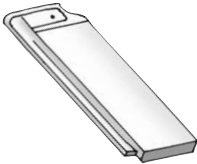
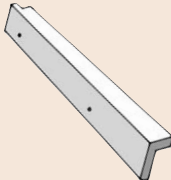
Celadon Accessories

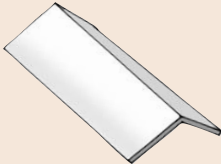
Tile Type	End Band	Detached Gable Rake Right and Left (Left Shown)	Rake Edge 90°	Hip & Ridge 100°
				
Actual Size	16"	16"	16"	16"
Exposure	13"	13"	13"	13"
Pieces/Box	80	150	36	36
Weight	4.0 lbs./ft.	2.1 lbs./ft.	6.3 lbs./ft.	6.3 lbs./ft.

French Interlocking Profile Tile

French

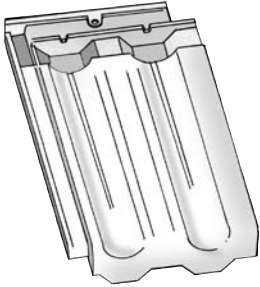

General Information

Overall Size	Average Exposure	Pcs./Square	Lbs./Square	Minimum Slope
9" x 16 1/4"	8 1/8" x 13 3/8"	133	1,025	3:12

Field Tile Accessories

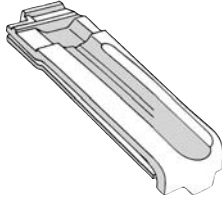
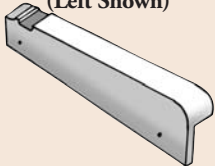
Tile Type	End Band	Detached Gable Rake Right & Left (Left Shown)
		
Actual Size	16 1/4"	16 1/4"
Exposure	13 3/8"	13 3/8"
Pieces/Box	32	32
Weight	5.7 lbs./ft.	2.9 lbs./ft.

No. 102 & No. 206 Hip & Ridge Accessories

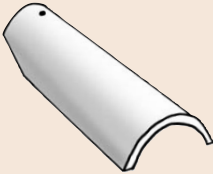
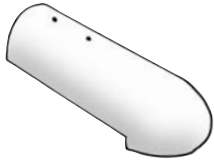
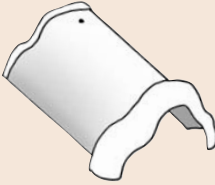
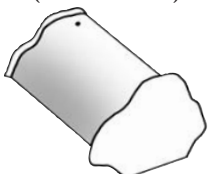
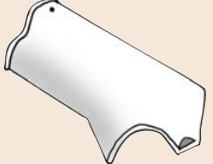
Tile Type	102 Hip Roll	152 Hip Starter	206 Ridge	206 Closed Ridge End* (Starter Shown)	102/206 Terminal 2H - 1R* (Starter Shown)
					
Actual Size	14 1/4"	14"	13 3/4"	14"	—
Exposure	12"	12"	12"	12"	—
Pieces/Box	30	4	12	2	2
Weight	5.2 lbs./ft.	6.3 lbs./pc.	11.5 lbs./ft.	18.0 lbs./pc.	17.0 lbs./pc.

*Starters and Finishers available, specify pitch of all sides of roof.

Spanish Tile (S-Tile)

Spanish Tile

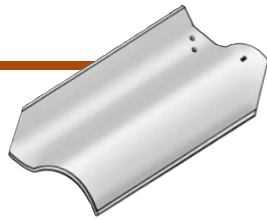

General Information

Length	Overall Size	Average Exposure	Pcs./Square	Lbs./Square	Minimum Slope
13 1/4"	9 3/4" x 13 1/4"	8 1/4" x 10 1/4"	171	900	4:12
18 3/8"	9 3/4" x 18 3/8"	8 1/4" x 15 3/8"	114	800	4:12

Field Tile Accessories

Tile Type	End Band	Detached Gable Rake Right & Left (Left Shown)	Top Fixture	Eave Closure	Rolled Rake
Actual Size	13 1/4"	13 1/4"	—	—	13 1/4"
	18 3/8"	18 3/8"	—	—	18 3/8"
Exposure	13 1/4"	10 1/4"	8 1/4"	8 1/4"	10 1/4"
	18 3/8"	15 3/8"	—	—	15 3/8"
Pieces/Box	80	200	225	225	80
Weight	13 1/4"	4.2 lbs./ft.	1.8 lbs./ft.	1.5 lbs./ft.	4.6 lbs./ft.
	18 3/8"	6.2 lbs./ft.	2.7 lbs./ft.	1.5 lbs./ft.	6.8 lbs./ft.

No. 102 & No. 206 Hip & Ridge Accessories

Tile Type	102 Hip Roll	152 Hip Starter	206 Ridge	206 Closed Ridge End* (Starter Shown)	102/206 Terminal (Starter Shown)
Actual Size	14 1/4"	14"	13 3/4"	14"	—
Exposure	12"	12"	12"	12"	—
Pieces/Box	30	4	12	2	2
Weight	5.2 lbs./ft.	6.3 lbs./pc.	11.5 lbs./ft.	18.0 lbs./pc.	17.0 lbs./pc.

Circular Cover Hip & Ridge Accessories

Tile Type	Circular Cover Hip & Ridge	Circular Cover Hip Starter	Circular Cover Closed Ridge End* (Starter Shown)	Circular Cover Terminal 2H-1R* (Starter Shown)
Actual Size	16"	14 1/4"	16 1/2"	—
Exposure	13"	12"	13"	—
Pieces/Box	40	4	4	2
Weight	5.8 lbs./ft.	9.0 lbs./pc.	9.8 lbs./pc.	10.0 lbs./pc.

*Starters and Finishers available, specify pitch of all sides of roof.

Pan & Cover Tile

Straight Barrel Mission & Palm Beach

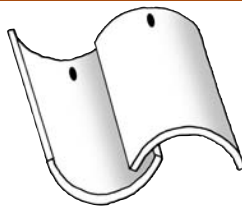

General Information

Length	Overall Size	Length Exposure	Width Exposure	Pcs./ Square	Lbs./ Square	Minimum Slope
14 1/4"	8" x 14 1/4"	11 1/4"	P = 3 1/2" C = 8" CC = 11 1/2"	225	1,250	5:12
16"	8" x 16"	13"	P = 3 1/2" C = 8" CC = 11 1/2"	192	1,190	5:12
18 3/8" & Palm Beach	8" x 18 3/8"	15 3/8"	P = 3 1/2" C = 8" CC = 11 1/2"	163	1,165 1,100	5:12

P = Pan (*Pan Measurement at Butt of Tile) C = Cover (*Cover Measurement at Butt of Tile) CC = Center to Center Dimensions

Straight Barrel Mission & Palm Beach Accessories

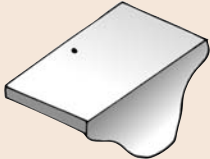
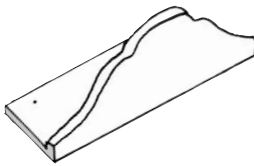
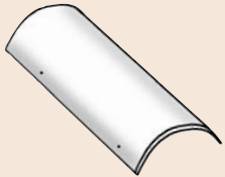
Tile Type	Top Fixture	Eave Closure	Rolled Rake*
			
Actual Size	—	—	14 1/4" 16" 18 3/8" & Palm Beach
Exposure	11 1/2"	11 1/2"	11 1/4" 13" 15 3/8"
Pieces/Box	90	90	40
Weight	2.0 lbs./ft.	2.6 lbs./ft.	5.5 lbs./ft. 6.1 lbs./ft. 7.1 lbs./ft.

*Rolled Rake for Palm Beach is 3/4 Rolled Rake.

Greek, Roman, Italian

General Information

Tile Type	Overall Size	Length Exposure	Width Exposure	Pcs./ Square	Lbs./ Square	Minimum Slope
Greek & Roman	P*=9 3/4" x 12 3/4" C*=6 1/2" x 12 3/4"	10"	P = 5 1/2" C* = 6 1/2" CC = 12"	240	1,550	4:12
Italian Pans & 18 3/8" Palm Beach Mission Covers	P=9 9/16" x 18 3/8" C=8" x 18 3/8"	15 3/8"	P = 4" C = 8" CC = 12"	156	1,100	5:12

P = Pan (*Pan Measurement at Butt of Tile) C = Cover (*Cover Measurement at Butt of Tile) CC = Center to Center Dimensions

Note: For Italian Pan & Covers, multiple combinations are possible. Please contact Ludowici Roof Tile for special instructions.

Pan & Cover Tile continued on next page.

Pan & Cover Tile (continued)

Tapered Mission

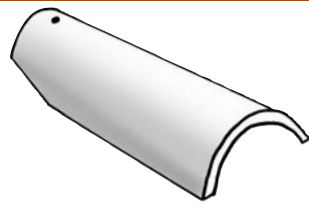

General Information

Length	Overall Size	Length Exposure	Width Exposure	Pcs./Square	Lbs./Square	Minimum Slope
16" Tapered Mission & Straight Pans*	P = 8" x 16" C = 7" x 16"	13"	P = 3 1/2" C = 7" CC = 10 1/2"	212	1,230	5:12
16" Tapered Mission Cover & Tapered Pans	7" x 16"	13"	P = 2" C = 7" CC = 9"	246	1,300	5:12

*Recommended Laid Tight Method

P = Pan (Pan Measurement at Butt of Tile) C = Cover (Cover Measurement at Butt of Tile) CC = Center to Center Dimensions

Tapered Mission Accessories

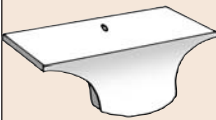
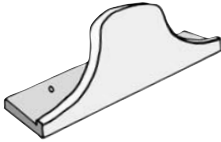
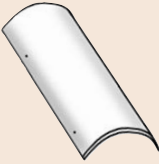
Tile Type	Top Fixture	Eave Closure	Rolled Rake
			
Actual Size	—	—	16"
Exposure	10 1/2" w/SBM pans 9" w/tapered pans	10 1/2" w/SBM pans 9" w/tapered pans	13"
Pieces/Box	90	90	40
Weight	2.4 lbs./ft.	3.2 lbs./ft.	6.1 lbs./ft.

Laid Tight Method Accessories

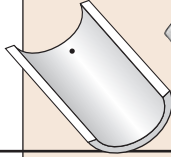
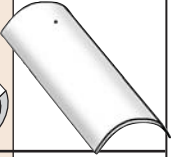
Tile Type	Finisher Pan	Starter Cover
		
14 1/4"		
Actual Size	11 1/4"	11 1/4"
Exposure	8 1/4"	8 1/4"
Pieces/Pallet	540	540
16"		
Actual Size	13"	13"
Exposure	10"	10"
Pieces/Pallet	540	540
18 3/8"		
Actual Size	15 3/8"	15 3/8"
Exposure	12 3/8"	12 3/8"
Pieces/Pallet	540	540

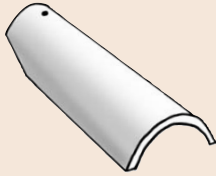
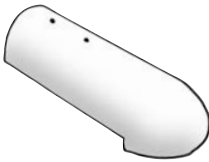
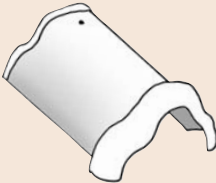
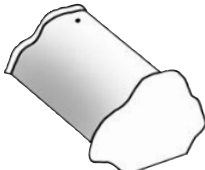
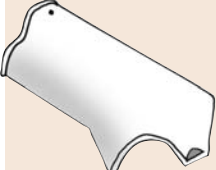

No. 102 & No. 206 Hip & Ridge Accessories

Tile Type	102 Hip Roll	152 Hip Starter	206 Ridge	206 Closed Ridge End* (Starter Shown)	102/206 Terminal (Starter Shown)
					
Actual Size	14 1/4"	14"	13 3/4"	14"	—
Exposure	12"	12"	12"	12"	—
Pieces/Box	30	4	12	2	2
Weight	5.2 lbs./ft.	6.3 lbs./pc.	11.5 lbs./ft.	18.0 lbs./pc.	17.0 lbs./pc.

Pan & Cover Tile (continued)

Tapered Mission

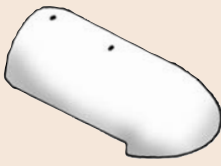
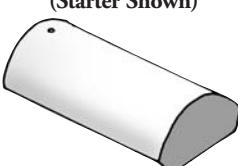
Circular Cover Hip & Cover Accessories

Tile Type	Circular Cover Hip & Ridge	Circular Cover Hip Starter	Circular Cover Closed Ridge End* (Starter Shown)	Circular Cover Terminal 2H-1R* (Starter Shown)
				
Actual Size	16"	14 1/4"	16 1/2"	—
Exposure	13"	12"	13"	—
Pieces/Box	40	4	4	2
Weight	5.8 lbs./ft.	9.0 lbs./pc.	9.8 lbs./pc.	10.0 lbs./pc.

*Starters and Finishers available, specify pitch of all sides of roof.

Attachment Requirements

Tile Type	Fastener Length			Height of Cant Strip	Quik-Tach™ Brackets	Hurricane Clips
	For Field Tile	For Hip	For Ridge			
Flat Shingle Tiles						
Flat Slab Shingle 3/8"	Boards: 1 1/2" Plywood: 1 3/4"	2"	Header Course: 1 1/2" V-Type: 2 1/2"	3/4" x 2" + Under Eave Fitting	Type C*	N/A
Flat Slab Shingle 5/8"	Boards: 1 3/4" Plywood: 2"	2"	Header Course: 1 1/2" V-Type: 2 1/2"	1" x 2" + Under Eave Fitting	Type C*	N/A
Antique, Calais, Brittany, Crude, Colonial, Georgian, Norman, Provincial	Boards: 1 1/2" Plywood: 1 3/4"	2"	Header Course: 1 1/2" V-Type: 2 1/2"	1" x 2" + Under Eave Fitting	Type C*	N/A
Interlocking Tiles						
Americana, Americana XL, Classic, Classic XL, Lanai, Lanai XL, Williamsburg, Williamsburg XL, Celadon	Boards: 1 3/4" Plywood: 2"	2"	2 1/2"	Under Eave Fitting	Type C*	On Eave: 3/4" Above Eave: 1 1/4"
Interlocking Profile Tiles						
French	Boards: 2" Plywood: 2 1/2"	2"	2 1/2"	1 1/2" x 2"	Not Required	1 3/4"
S-Tiles						
Spanish 18 3/8", 13 1/4"	Boards: 1 1/2" Plywood: 1 3/4"	2"	2 1/2"	Eave Closure	Type B Type D: 18 3/8"	On Eave: 3/4" Above Eave: 2 5/16"
Pan & Cover Tiles						
Italian, Greek, Roman Straight Barrel Mission					N/A	N/A
14 1/4", 16", 18 3/8" & Palm Beach	2"	Boards: 1 1/2" Plywood: 1 3/4"	2"	2 1/2"	Eave Closure	Type B Type D: 14 1/4"
16" Tapered Mission	2"	Boards: 1 1/2" Plywood: 1 3/4"	2"	2 1/2"	Eave Closure	Type D Wind Locks

*Type C brackets must be cut or bent for these tile patterns.

Note 1:

Different Hip & Ridge accessories can be used on different tile styles. Please contact Ludowici Technical Service for more information.

Note 2:

Weight of actual tiles may vary by (+/-) 10% of the average weight. Weights listed are based on the recommended exposures. All structural load calculations should use a 1.1 multiplier for weights per square.

Impressionist Series

Through a totally unique process mastered by only Ludowici, the Impressionist Series utilizes two or three complimentary shades applied randomly over a base color to create the patina of a century old roof. No two tiles will ever have the same appearance, but due to the random color application they blend together to create harmonious roof aesthetics.

Color Disclaimer

Colors within a given shipment of Ludowici clay roof tile will vary slightly due to subtle changes in clay composition and kiln firing temperatures. Such color variances are not a defect but a natural, desirable feature that gives roofs depth and character.

Application in Alpine Conditions

Before application of Ludowici clay tile in alpine conditions (typically encountered at higher altitudes in heavy snow load areas), plans must be submitted to the Ludowici Technical Department (800-945-8453) for approval. Ludowici will not assume any liability or responsibility for damage caused by the application of clay tile in alpine conditions unless plans have been pre-approved in writing. (For more information, contact our Technical Service Department.)



4757 Tile Plant Road, P.O. Box 69, New Lexington, Ohio 43764
Telephone (740) 342-1995 (800) 945-8453 Fax (740) 342-5229 <http://www.ludowici.com>